



racks and transport cases

292	19" rack cabinets
294	19" rack flight cases
294	19" rack
299	19" rack flight cases manufactured in ABS
300	Trunks
302	Road cases and flight cases
302	DJ
302	For mixers
304	For microphone stands
305	For cabinet speakers
307	For flat screens
308	Trolley
309	Briefcases
310	Accessories for 19" racks

RACKS. 19" RACK CABINETS

19" rack cabinets for audio, lighting, data, communication equipment, etc.

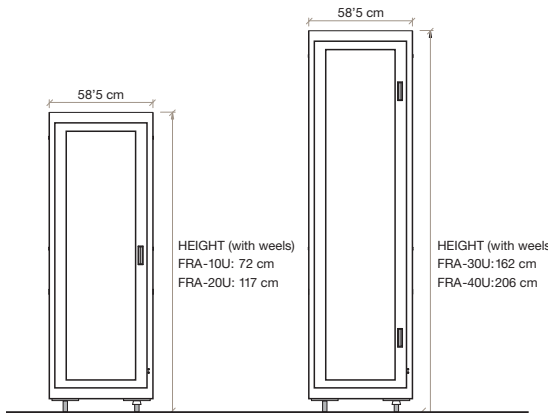

FRA-10U

FRA-20U

FRA-30U

FRA-40U

CHARACTERISTICS	FRA-10U	FRA-20U	FRA-30U	FRA-40U
CHARACTERISTICS	Metal 19" rack cabinet, transparent methacrylate door with lock and key, wheels with brakes, feet and 2 fans (230 V AC) in the top. Dismountable side and back panels. Cable holder on the side. Black enamel finish.	Metal 19" rack cabinet, transparent methacrylate door with lock and key, wheels with brakes, feet and 2 fans (230 V AC) in the top. Dismountable side and back panels. Cable holder on the side. Black enamel finish.	Metal 19" rack cabinet, transparent methacrylate door with 2 locks and keys, wheels with brakes, feet and 2 fans (230 V AC) in the top. Dismountable side and back panels. Cable holder on the side. Black enamel finish.	Metal 19" rack cabinet, transparent methacrylate door with 2 locks and keys, wheels with brakes, feet and 2 fans (230 V AC) in the top. Dismountable side and back panels. Cable holder on the side. Black enamel finish.
CAPACITY	10 U 19" rack = 44.5 cm	20 U 19" rack = 89 cm	30 U 19" rack = 133.5 cm	40 U 19" rack = 178 cm
DIMENSIONS	With wheels: 58.5 x 72 x 58.5 cm depth	With wheels: 58.5 x 117 x 58.5 cm depth	With wheels: 58.5 x 162 x 58.5 cm depth	With wheels: 58.5 x 206 x 58.5 cm depth
ACCESSORIES	Feet, 6 mounts, 1 tray, nuts and bolts for equipment assembly	Feet, 10 mounts, 1 tray, nuts and bolts for equipment assembly	Feet, 12 mounts, 1 tray, nuts and bolts for equipment assembly	Feet, 14 mounts, 1 tray, nuts and bolts for equipment assembly
WEIGHT	41 kg	56 kg	70 kg	84 kg
OPTIONAL	T-FRA: thermostat to activate the fans depending on the temperature	T-FRA: thermostat to activate the fans depending on the temperature	T-FRA: thermostat to activate the fans depending on the temperature	T-FRA: thermostat to activate the fans depending on the temperature



T-FRA

CHARACTERISTICS

Thermostat accessory for FONESTAR 19" rack cabinets, FRA series. The desired temperature can be selected between 0 and 60°, above which the 19" rack cabinet fan will be activated. Optimizes the fan, turning on only when required. Includes assembly accessory for 19" rack. Under petition, is supplied already installed in the upper back right or left part of the FONESTAR mods. FRA-10U, FRA-20U, FRA-30U and FRA-40U.

FP-12U

FP-18U

CHARACTERISTICS	Metal 19" rack cabinet, transparent methacrylate door with lock and key, open back and wheels with brake. Black enamel finish.	Metal 19" rack cabinet with transparent methacrylate door with lock and key, open back and wheels with brake. Black enamel finish.
CAPACITY	12 U 19" rack = 53.4 cm	18 U 19" rack = 80.1 cm
DIMENSIONS	With wheels: 55.5 x 69 x 50 cm depth	With wheels: 55.5 x 95 x 50 cm depth
WEIGHT	23.5 kg	28.8 kg
ACCESSORIES	12 angle mounts, nuts and bolts for equipment assembly	18 angle mounts, nuts and bolts for equipment assembly



FP-12U



FP-18U



FRL-12U

FRL-18U

FRL-24U

FRL-15U-F

FRL-24U-F

CHARACTERISTICS	Metal 19" rack cabinet, open back/front and wheels with brake. Black enamel finish.	Metal 19" rack cabinet, open back/front and wheels with brake. Black enamel finish.	Metal 19" rack cabinet, open back/front and wheels with brake. Black enamel finish.	Metal 19" rack cabinet, open front/back and wheels. Black enamel finish. Extra depth, 58 cm total.	Metal 19" rack cabinet, open front/bottom and wheels. Black enamelled finish. Extra deep, 58 cm in total.
CAPACITY	12 U 19" rack= 53.4 cm	18 x 19" U rack = 80.1 cm	24 U 19" rack = 106.8 cm	15 U 19" rack = 66.8 cm	24 U 19" rack = 106.8 cm
DIMENSIONS	With wheels: 55.5 x 71 x 45 cm depth	With wheels: 55.5 x 97 x 45 cm depth	With wheels: 55.5 x 124 x 45 cm depth	With wheels: 56 x 83 x 58 cm depth	With wheels: 56 x 123 x 58 cm depth
WEIGHT	19.7 kg	25 kg	28.3 kg	28.5 kg	36 kg
ACCESSORIES	12 angle mounts, nuts and bolts for equipment assembly	18 mounts, nuts and bolts for equipment assembly	24 angle mounts, nuts and bolts for equipment assembly	15 angle mounts, nuts and bolts for equipment assembly	24 angle brackets, nuts and bolts for equipment assembly



FW-6U



FW-12U

CHARACTERISTICS	19" rack cabinet for walls, metal, transparent methacrylate door and opening back panel with lock and key. Black enamel finish.	19" rack cabinet for walls, metal, transparent methacrylate door, and back opening with lock and key. Black enamel finish.
CAPACITY	6 U 19" Rack = 26.6cm	12 U 19" rack = 53.4cm
DIMENSIONS	Exterior: 54 x 34.5 x 50.5 cm depth Interior: 48.5 x 26.6 x 41 cm depth	Exterior: 54 x 61.5 x 50.5 cm depth Interior: 48.5 x 53.4 x 41 cm depth
WEIGHT	18 kg	26.6 kg
ACCESSORIES	4 angle mounts, nuts and bolts for equipment assembly.	4 angle mounts, nuts and bolts for equipment assembly.

RACKS. 19" RACK FLIGHT CASES

19" shock-resistant racks for audio and lighting equipment.

Manufactured in coated plywood. Protection against knocks in the form of 25 mm high density foam.

Hermetically closing front and back lids, carrying handles, wheels with brakes, metal protective corner covers.

Robust construction for transporting and the equipment assembled in the rack.

Black finish.



FRS-120



FRS-160

CHARACTERISTICS	FRS-120	FRS-160
	Antishock 19" racks in coated plywood. Protection against knocks in the form of 25 mm high density foam. Hermetically closing front and back lids, carrying handles, wheels with brakes, metal protective corner covers. Robust construction for transporting and protecting the equipment assembled in the rack. Black finish. Extra depth, 60 cm total.	
CAPACITY	12 U 19" rack = 53.4 cm	16 U 19" rack = 71.2 cm
DIMENSIONS	Exterior (with wheels): 60 x 80 x 77 cm depth Interior: 48.5 x 55 x 57 cm depth	Exterior (with wheels): 60 x 97.5 x 77.5 cm depth Interior: 48.5 x 71.2 x 57 cm depth
WEIGHT	41.4 kg	47 kg
ACCESSORIES	Nuts and bolts for equipment assembly	Nuts and bolts for equipment assembly

19" racks with top mount for audio equipment, DJ mixer, mixers, lighting equipment, etc.



FRM-104

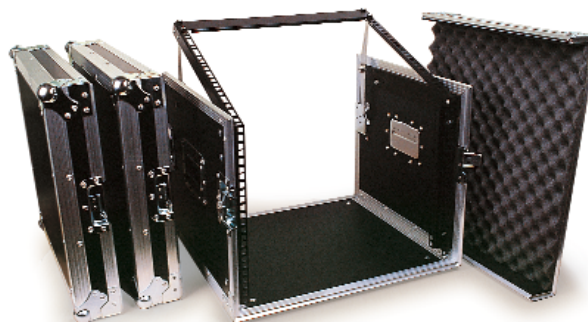

FRM-108

CHARACTERISTICS	FRM-104	FRM-108
	19" rack with top mount for audio and lighting equipment. Manufactured in coated plywood. Hermetically closing lid with foam protection inside. Carrying handles, rubber feet and metal protective corner pieces. Robust construction for transporting and protecting the equipment in the rack. Black finish.	19" rack with top mount for audio and lighting equipment. Manufactured in coated plywood. Hermetically closing lid with foam protection inside. Carrying handles, rubber feet and metal protective corner pieces. Robust construction for transporting and protecting the equipment in the rack. Black finish.
CAPACITY	4 U 19" rack = 17.8 cm front 9 U x 19" rack = 40.1 cm top mount	8 U x 19" rack = 35.6 cm front 9 U x 19" rack = 40.1 cm top mount
DIMENSIONS	Exterior: 53 x 29.5 x 62 cm depth Interior (upper space): 48.5 x 7.5 x 40.1 cm depth Interior (lower space): 48.5 x 17.8 x 45 cm depth	Exterior: 53 x 47 x 62 cm depth Interior (upper space): 48.5 x 7.5 x 40.1 cm depth Interior (lower space): 48.5 x 35.6 x 45 cm depth
WEIGHT	14.5 kg	18.5 kg
ACCESSORIES	Nuts and bolts for equipment assembly	Nuts and bolts for equipment assembly.

19" racks with top mount for audio equipment, DJ mixer, mixers, lighting equipment, etc.



FRM-130



FRM-170

CHARACTERISTICS	Antishock 19" rack with top mount for audio and lighting equipment. Manufactured in coated plywood. High density 25mm foam protection. Hermetically closing lids for the front, back and top. Carrying handles, wheels with brake and metal protective corner pieces. Robust construction for transporting and protecting the equipment assembled in the rack. Black finish.	
CAPACITY	12 U 19" rack = 53.4 cm front 9 U 19" rack = 40.1 cm top mount	16 U 19" rack = 71.2 cm front 9 U 19" rack = 40.1 cm top mount
DIMENSIONS	Exterior (with wheels): 60 x 100.5 x 67.5 cm depth Interior (upper space): 48.5 x 14.5 x 40.1 cm depth Interior (lower space): 48.5 x 53.4 x 50 cm depth	Exterior (with wheels): 60 x 118.5 x 67.5 cm depth Interior (upper space): 48.5 x 14.5 x 40.1 cm depth Interior (lower space): 48.5 x 71.2 x 50 cm depth
WEIGHT	45 kg	51 kg
ACCESSORIES	Nuts and bolts for equipment assembly	Nuts and bolts for equipment assembly

FRM-130

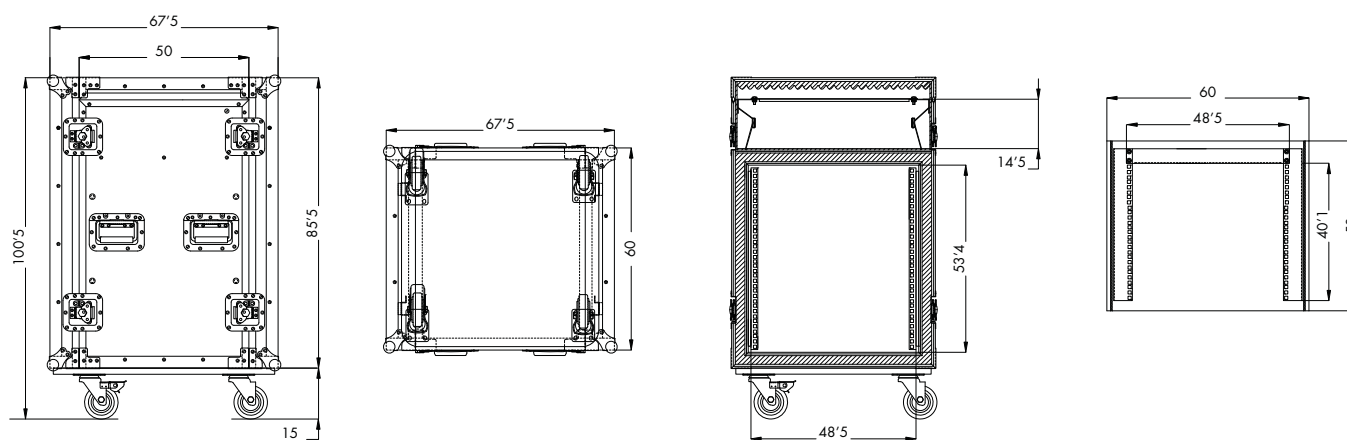

RACKS. 19" RACK FLIGHT CASES

Shock-resistant 19" rack with 2 lids (front and back), that can be converted into tables and a top mount for audio and lighting equipment.



FRM-135



FRM-175



FRM-135

FRM-175

CHARACTERISTICS	FRM-135	FRM-175
	Antishock 19" rack with 2 lids (front and back), that can be converted into tables. In coated plywood. Protection against knocks with high density 25 mm foam. Hermetically closing front, back and top lids, transport handles, wheels with brake and metal protective corner covers. Robust construction for transporting and protecting the equipment assembled in the rack. Black finish.	
CAPACITY	12U 19" rack = 53.4 cm front 9 U 19" rack = 40.1 cm top mount	16 U 19" rack = 71.2 cm front 9 U 19" rack = 40.1 cm top mount
DIMENSIONS	Exterior (with wheels): 60 x 100.5 x 67.5 cm depth Interior (upper space): 48.5 x 14.5 x 40.1 cm depth Interior (lower space): 48.5 x 53.4 x 50 cm depth Tables: 85.5 x 60 cm depth, height 80 cm	Exterior (with wheels): 60 x 118.5 x 67.5 cm depth Interior (upper space): 48.5 x 14.5 x 40.1 cm depth Interior (lower space): 48.5 x 71.2 x 50 cm depth Tables: 103.5 x 60 cm depth, height 98 cm
WEIGHT	51.6 kg	59 kg
ACCESSORIES	Nuts and bolts for equipment assembly	Nuts and bolts for equipment assembly

19" racks for audio and lighting equipment.



FRE-202

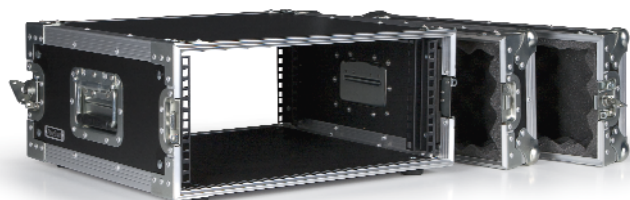

FRE-204



FRE-207

FRE-202

FRE-204

FRE-207

CHARACTERISTICS	19" rack in coated plywood, hermetically closing front and back lids with protective foam, transport handles, rubber feet and metal protective corner covers. Robust construction for transporting and protecting the equipment assembled in the rack. Black finish.		
CAPACITY	2 U 19" rack = 8.9 cm	4 U 19" rack = 17.8 cm	10 U 19" rack = 44.5 cm
DIMENSIONS	Exterior: 52 x 12.5 x 40 cm depth Interior: 48.5 x 8.9 x 26.5 cm depth	Exterior: 53 x 22 x 62 cm depth Interior: 48.5 x 17.8 x 45 cm depth	Exterior: 53 x 48.5 x 67.5 cm depth Interior: 48.5 X 44.5 X 47 cm depth
WEIGHT	4.5 kg	12 kg	18 kg
ACCESSORIES	Nuts and bolts for equipment assembly	Nuts and bolts for equipment assembly	Nuts and bolts for equipment assembly

19" rack for double CD player or similar.



FRE-200 + CD-4500DJ



FRE-200

CHARACTERISTICS	19" rack for double CD player or similar. Manufactured in coated plywood. Hermetically closing front and back lids, carrying handles, rubber feet, and metal protective corner pieces. Robust construction for transporting and protecting the equipment assembled in the rack. Black finish.
CAPACITY	3 U 19" rack = 13.3 cm for the control unit 3 U 19" rack = 13.3 cm for the main unit
DIMENSIONS	Exterior: 53 x 18 x 58 cm depth Interior (upper space): 48.5 x 13.3 x 8 cm depth Interior (lower space): 48.5 x 13.3 x 28 cm depth
WEIGHT	6.3 kg
ACCESSORIES	Nuts and bolts for equipment assembly

RACKS. 19" RACK FLIGHT CASES

19" racks for audio and lighting equipment.



FRE-206



FRE-209

CHARACTERISTICS	19" rack for audio and lighting equipment. Manufactured in coated plywood, open back/front, carrying handles, rubber feet, and metal protective corner pieces. Robust construction for transporting and protecting the equipment assembled in the rack. Black finish.	19" rack for audio and lighting equipment. Manufactured in coated plywood, open back/front, carrying handles, rubber feet, and metal protective corner pieces. Robust construction for transporting and protecting the equipment assembled in the rack. Black finish.
CAPACITY	8 U 19" rack = 35.6 cm	12 U 19" rack = 53.4 cm
DIMENSIONS	Exterior: 53 x 39.5 x 49 cm depth Interior: 48.5 x 35.6 x 45 cm depth	Exterior: 53 x 58 x 49 cm depth Interior: 48.5 x 53.4 x 45 cm depth
WEIGHT	10 kg	13 kg
ACCESSORIES	Nuts and bolts for equipment assembly	Nuts and bolts for frontal assembly of equipment



FRE-208



FRE-210

CHARACTERISTICS	19" rack with separate top section. Manufactured in coated plywood, hermetically closing top lid, open back/front, carrying handles, wheels with brakes, and metal protective corner pieces. Robust construction for transporting and protecting the equipment assembled in the rack. Black finish.	19" rack with transparent door, and lock and key. Manufactured in coated plywood, door opens either to the left or to the right. Open backed cabinet with carrying handles, wheels with brakes and metal protective corner pieces. Robust construction for transporting and protecting the equipment assembled in the rack. Black finish.
CAPACITY	12 U 19" rack = 53.4 cm	16 U 19" rack = 71.2 cm
DIMENSIONS	Exterior (with wheels): 52.5 x 91 x 50.5 cm depth Interior (lid): 49 x 17 x 47 cm depth Interior (cabinet): 48.5 x 53.4 x 47 cm depth	Exterior (with wheels): 53 x 90 x 54 cm depth Interior: 48.5 x 71.2 x 45 cm depth
WEIGHT	22 kg	23.6 kg
ACCESSORIES	Nuts and bolts for equipment assembly	Nuts and bolts for equipment assembly

RACKS. 19" RACK FLIGHT CASES MANUFACTURED IN ABS

FONESTAR

Lightweight stackable ABS 19" racks, with carrying handles and front and back covers.



FAB-2



FAB-4 + CD-4400DJ



FAB-4



FAB-8

FAB-2

FAB-4

FAB-8

CHARACTERISTICS	19" lightweight stackable racks for audio and lighting equipment. Manufactured in ABS, front and back covers with hermetic closing, with handles for transporting. Robust, light structure for transporting and protecting the equipment inside. Black finish.	19" lightweight stackable racks for audio and lighting equipment. Manufactured in ABS, hermetically closing front and back covers, with handles for transporting. Robust, lightweight construction for transporting and protecting the equipment inside. Black finish.	19" lightweight stackable racks for audio and lighting equipment. Manufactured in ABS, front and back covers with hermetic closing, with handles for transporting. Robust, lightweight construction for transporting and protecting the equipment inside. Black finish.
CAPACITY	2 U 19" racks = 8.9 cm	4 U 19" racks = 17.8 cm	8 U 19" racks = 35.6 cm
DIMENSIONS	Exterior: 55 x 16 x 56.5 cm depth Interior: 48.5 x 9 x 41.5 cm depth	Exterior: 55 x 24.5 x 56.5 cm depth Interior: 48.5 x 18 x 41.5 cm depth	Exterior: 55 x 42 x 56.5 cm depth Interior: 48.5 x 36 x 41.5 cm depth
WEIGHT	4 kg	4.8 kg	6.8 kg
ACCESSORIES	Screws for equipment assembly	Screws for equipment assembly	Screws for equipment assembly

ROAD AND FLIGHT CASES. TRUNKS

Flight trunks for a variety of equipment.



FRC-263
FRC-265



FRC-267
FRC-269

FRC-263

Flight trunks without internal divisions. Manufactured in coated plywood and lined with foam. Hermetically closing lid, carrying handles, wheels with brakes, and protective metal corner pieces. Robust construction for transporting and protecting different types of material. Black finish.

FRC-265

Flight case trunks without internal divisions. Manufactured in coated plywood and lined with foam. Hermetically closing lid, carrying handles, wheels with brakes, and protective metal corner pieces. Robust construction for transporting and protecting different types of material. Black finish.

FRC-267

Flight trunks with internal divisions. Manufactured in coated plywood and lined with foam. Hermetically closing lid, carrying handles, wheels with brakes, and protective metal corner pieces. Robust construction for transporting and protecting different types of material. Black finish.

FRC-269

Flight trunks with internal divisions. Manufactured in coated plywood and lined with foam. Hermetically closing lid, carrying handles, wheels with brakes, and protective metal corner pieces. Robust construction for transporting and protecting different types of material. Black finish.

CHARACTERISTICS	FRC-263	FRC-265	FRC-267	FRC-269
DIVISIONS	-	-	8 internal divisions measuring 23 x 23 x 20 cm height	4 internal divisions measuring 47 x 35 x 55 cm height
DIMENSIONS	Exterior (with wheels): 110.5 x 65 x 55.5 cm depth Interior: 106.5 x 47.5 x 51.5 cm depth	Exterior (with wheels): 120 x 75.5 x 60.5 cm depth Interior: 116.5 x 56.5 x 56.5 cm depth	Exterior (with wheels): 103 x 75.5 x 51 cm depth Interior: 99 x 57 x 47.5 cm depth	External (with wheels): 100.5 x 74.5 x 75.5 depth Internal: 97.5 x 55.5 x 72 cm depth
WEIGHT	36 kg	40.5 kg	37.5 kg	44.5 kg

FRC-269

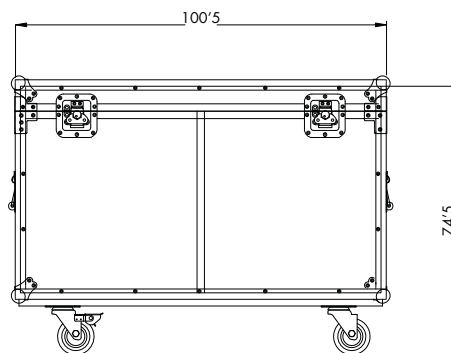
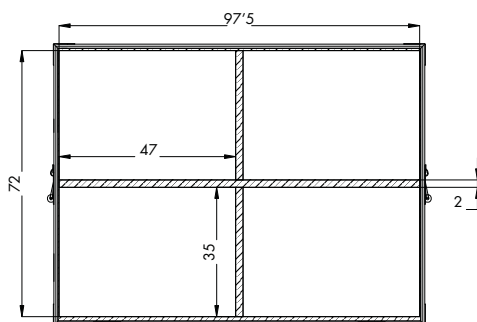
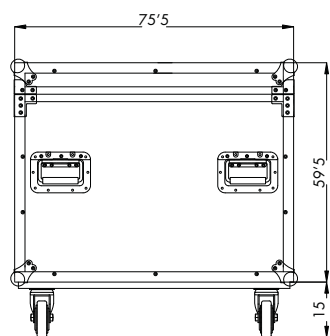

Stackable flight trunk.



FRC-262A

CHARACTERISTICS	Stackable flight trunk with small reinforced trays in the lid to stack trunks with wheels. Manufactured in coated plywood and lined with foam. Hermetically closing lid, carrying handles, wheels with brake and metal protective corner covers. Robust construction for transporting and protecting a variety of material. Black finish.
DIMENSIONS	Exterior (with wheels): 110.5 x 65 x 55.5 cm depth Interior: 106.5 x 47.5 x 51.5 cm depth
WEIGHT	33 kg



Flight case for a variety of equipment.

FRC-261

CHARACTERISTICS	Flight case. Manufactured in coated plywood, with 4 sliding drawers and a hermetically closing door, carrying handles and protective metal corner pieces. Robust construction for transporting and protecting different types of material. Black finish.
DIMENSIONS	External (with wheels): 53 x 90.5 x 59.5 cm depth Internal (small drawer): 44.5 x 12 x 46 cm depth Internal (large drawer): 44.5 x 22.5 x 46 cm depth
WEIGHT	46 kg



ROAD AND FLIGHT CASES. DJ

DJ transport case for mixers, CD players, turntables, etc.



FRC-281



FRC-283/FRC-285



FRC-283



FRC-283/FRC-285

FRC-281

FRC-283

FRC-285

CHARACTERISTICS

DJ transport case for mixers, CD players, turntables, etc.

In coated plywood with foam lining, 3 divisions for installing 2 individual CDs or 2 turntables and 1 central mixer for use as a portable disco, back opening for the mixer cables and grommets between divisions; hermetically closing lid, transport handles, rubber feet and protective metal corner covers.

Robust construction for transporting and protecting equipment.
Black finish.

DIMENSIONS

Exterior: 105 x 22 x 56 cm depth
Interior (for each turntable): 37 x 12.5 x 45 cm depth
Interior (for the table): 18.5-25 (adjustable foam) x 12.5 x 22-45 cm depth

Exterior: 96 x 26 x 44.5 cm depth
Interior (for each CD): 24 x 20.5 x 33 cm depth
Interior (for the table): 35 x 20.5 x 33 cm depth

Exterior: 117 x 22.5 x 49.5 cm depth
Interior (for each CD): 35.5 x 17 x 38 cm depth
Interior (for the table): 33 x 17 x 38 cm depth

WEIGHT

18.8 kg

16.6 kg

18.6 kg

ACCESSORIES

-

Extra foam

-

FRC-283 and FRC-285

- FRC-283
- FRC-285

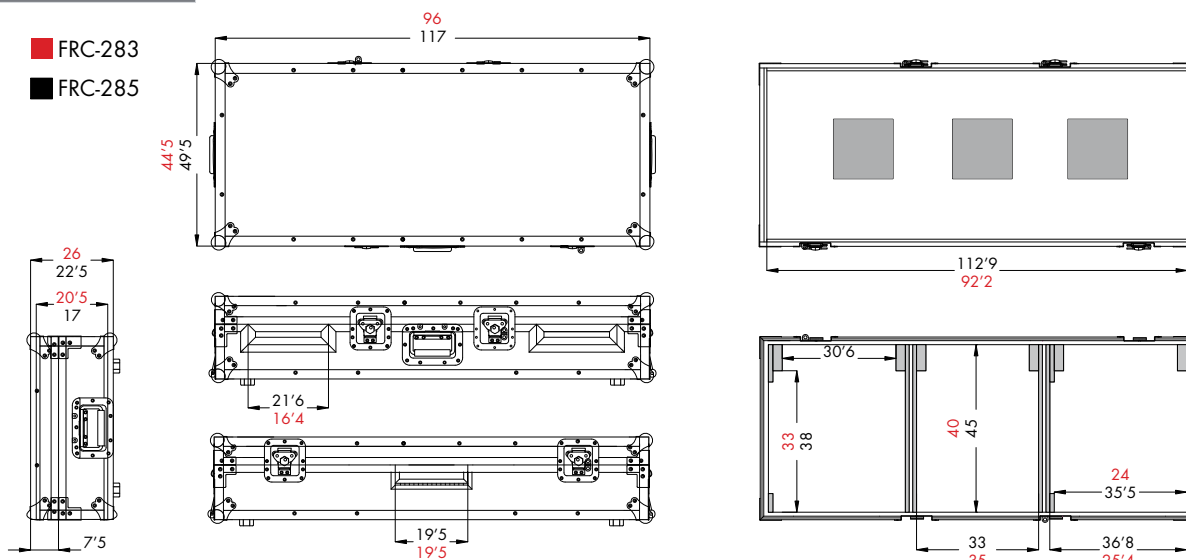

ROAD AND FLIGHT CASES. MIXER

FONESTAR

Flight cases for mixers and a variety of equipment.



FRC-287

CHARACTERISTICS Flight case for professional mixer or similar equipment. Manufactured in coated plywood and lined with foam, includes an adjustable internal system for different sized mixers. A hermetically closing lid, carrying handles, rubber feet and protective metal corner pieces. Robust construction for transporting and protecting the equipment inside. Black finish.

CAPACITY

-

DIMENSIONS

Exterior: 94.5 x 30.5 x 53.5 cm depth
Interior: 87 x 25 x 46 cm depth

WEIGHT

19.6 kg

ACCESSORIES

-



FRC-289

CHARACTERISTICS 19" rack flight case for professional mixer or other equipment. Manufactured in coated plywood. 19" rack mount with adjustable inclination. Hermetically closing lid, carrying handles, rubber feet, and metal protective corner pieces. Robust construction for transporting and protecting the equipment inside the rack. Black finish.

CAPACITY 12 U 19" rack = 53.4 cm

DIMENSIONS Exterior: 51.5 x 27 x 58.5 cm depth
Interior: 48.5 x 18 x 53.4 cm depth

WEIGHT 7.9 kg

ACCESSORIES Nuts and bolts for equipment assembly



FRC-291

FRC-290

CHARACTERISTICS 19" flight case for professional mixer or a variety of equipment. Compatible with Allen & Heath Mix Wiz mixers and similar. Manufactured in coated plywood. Mount for 19" rack. Hermetically closing lid, carrying handles, rubber feet and metal protective corner pieces. Robust construction for transporting and protecting the equipment inside. Black finish.

CAPACITY

12 U 19" rack = 53.4 cm

DIMENSIONS

Exterior: 68 x 24 x 54 cm depth
Interior: 48.5 x 10.5 x 19.5 x 53.4 cm depth

WEIGHT

12.1 kg

ACCESSORIES

Bolts and washers for equipment assembly

FRC-291

CHARACTERISTICS Flight case for professional mixer or similar equipment. Manufactured in coated plywood and lined with foam, including an adjustable internal system for different sized mixers. Opening in the back for the mixer cables, hermetically closing lid, carrying handles, rubber feet and metal protective corner pieces. Robust construction for transporting and protecting the equipment inside. Extra foam included to change the interior for different sized equipment. Suitable for FONESTAR mixing table, mod. SMA-12800U and SM-3520U. Black finish.

CAPACITY

DIMENSIONS Exterior: 76 x 32.5 x 68 cm depth
Interior: 68 x 26.5 x 60.5 cm depth

WEIGHT 25 kg

ACCESSORIES Extra foam

ROAD AND FLIGHT CASES. MICROPHONE STANDS

Flight case for microphone stands or a variety of equipment.



FRC-270

CHARACTERISTICS Flight case for microphone stands or a variety of equipment. Manufactured in coated plywood with foam lining, hermetically closing lid, carrying handles, wheels and protective metal corner pieces. Robust construction for transporting and protecting microphone stands or different types of material. Black finish.

DIVISIONS

-

DIMENSIONS

Exterior (with wheels): 122.5 x 44 x 42.5 cm depth
Interior: 117 x 37.5 x 37 cm depth

WEIGHT

24 kg

FRC-271

CHARACTERISTICS Flight case for microphone stands. Manufactured in coated plywood, hermetically closing lid with foam lining, carrying handles, wheels with brake and protective metal corner pieces. Robust construction for transporting and protecting microphone stands. Black finish.

DIVISIONS 20 internal divisions of 11 cm Ø x 99 cm height

DIMENSIONS Exterior (with wheels): 59.5 x 126.5 x 48.5 cm depth
Interior: 56 x 108.5 x 45 cm depth

WEIGHT 61.8 kg

Transport cases for loudspeakers.



FAL-12

FAL-15

FAL-12

CHARACTERISTICS

Transport case for loudspeakers. In coated plywood with foam lining, hermetically closing lid, transport handles, wheels with brake and metal protective corner covers. Robust construction for transporting and protecting different materials. Black finish. Suitable for transporting 12" loudspeakers with the most common dimensions on the market (e.g. FONESTAR loudspeakers, mods. SB-3421, SB-3520, SB-3612, ASB-12300, ASB-12150U, etc).

DIMENSIONS

Exterior (with wheels): 50 x 89 x 45 cm depth
Interior: 44 x 67 x 38.5 cm depth

WEIGHT

23.2 kg

ACCESSORIES

Extra foam

FAL-15

Transport case for loudspeakers. In coated plywood and foam lining, hermetically closing lid, transport handles, wheels with brake and metal protective corner covers. Robust construction for transporting and protecting different material. Black finish.

Suitable for transporting 15" loudspeakers with the most common dimensions on the market (e.g. FONESTAR loudspeakers, mods. SB-3432, SB-3530, SB-3615, ASB-15300, ASB-15180U, etc).

Exterior (with wheels): 56 x 100 x 52 cm depth
Interior: 50 x 77 x 45.5 cm depth

27.8 kg

Extra foam

Transporting platform with wheels.



FRT-40

CHARACTERISTICS

Transporting platform with wheels. Manufactured in plywood, wheels with brake, handles and safety strap. Black finish.

DIMENSIONS

45 x 15 x 50 cm depth

WEIGHT

5.9 kg

ACCESSORIES

3.6 cm width and 3 m length safety strap

ROAD AND FLIGHT CASES. LOUDSPEAKERS

Transport cases with internal division for 2 loudspeakers.



FAL-24D
FAL-30D



FAL-24D



FAL-30D

FAL-24D

CHARACTERISTICS

Transport case with internal division for 2 loudspeakers. In coated plywood with foam lining, hermetically closing lid, transport handles, wheels with brake and protective metal corner covers. Robust construction for transporting and protecting different materials. Black finish. Suitable for transporting 2 x 12" loudspeakers with the most common dimensions on the market (e.g. FONESTAR loudspeakers, mods. SB-3421, SB-3520, SB-3612, ASB-12300, ASB-12150U, etc).

DIMENSIONS

Exterior (with wheels): 87 x 88 x 50 cm depth
Interior (for each cabinet speaker): 38.5 x 67 x 44 cm depth

WEIGHT

42.8 kg

ACCESSORIES

Extra foam

FAL-30D

Transport case with internal division for 2 loudspeakers. In coated plywood with foam lining, hermetically closing lid, transport handles, wheels with brake and metal protective corner covers.

Robust construction for transporting and protecting different materials. Black finish.

Suitable for transporting 2 x 15" loudspeakers with the most common dimensions on the market (e.g. FONESTAR loudspeakers, mods. SB-3432, SB-3530, SB-3615, ASB-15300, ASB-15180U, etc.)

Exterior (with wheels): 101 x 99.5 x 56 cm depth
Interior (for each cabinet speaker): 45.5 x 77 x 50 cm depth

49 kg

Extra foam

ROAD AND FLIGHT CASES. FLAT SCREENS

FONESTAR

Transport cases for 2 flat screens.



FPL-42D
FPL-50D
FPL-52XL

FPL-42D

FPL-50D

FPL-52XL

CHARACTERISTICS	FPL-42D	FPL-50D	FPL-52XL
CHARACTERISTICS	Transport case for 2 flat screens up to 42". In coated plywood with foam lining; internal divisions for 2 plasma monitors and additional side compartment for 2 mounts or different materials; hermetically closing lid, transport handles, wheels with brake and metal protective corner covers. Robust construction. Black finish.	Transport case for 2 flat screens up to 50". In coated plywood with foam lining. Internal divisions for 2 plasma screens with additional space on the side for 2 mounts or a variety of material. Hermetically closing lid, carrying handles, wheels with brake and protective metal corner covers. Robust construction. Black finish.	Transport case for 2 flat screens up to 50". In coated plywood with foam lining. Internal divisions for 2 flat screens with additional space on the side for 2 mounts or a variety of material. Hermetically closing lid, carrying handles, wheels with brake and protective metal corner covers. Robust construction. Black finish.
DIMENSIONS	Exterior: 110.5 x 85 x 53 cm depth Interior (for each monitor): 103.5 x 64.5 x 11 cm depth Interior (for each mount): 73.5 x 64.5 x 10.5 cm depth	Exterior: 132.5 x 97 x 55 cm depth Interior (for each monitor): 125.5 x 76.5 x 12 cm depth Interior (for each mount): 95.5 x 76.5 x 10.5 cm depth	Exterior: 141 x 105 x 56 cm depth Interior (for each monitor): 134 x 85 x 12.5 cm depth Interior (for each mount): 97.5 x 85 x 10.5 cm depth
WEIGHT	51 kg	66 kg	65 kg
ACCESSORIES	Extra foam with velcro to change divisions	Extra foam with velcro to change divisions	Extra foam with velcro to change divisions

FPL-42D, FPL-50D & FPL-52XL

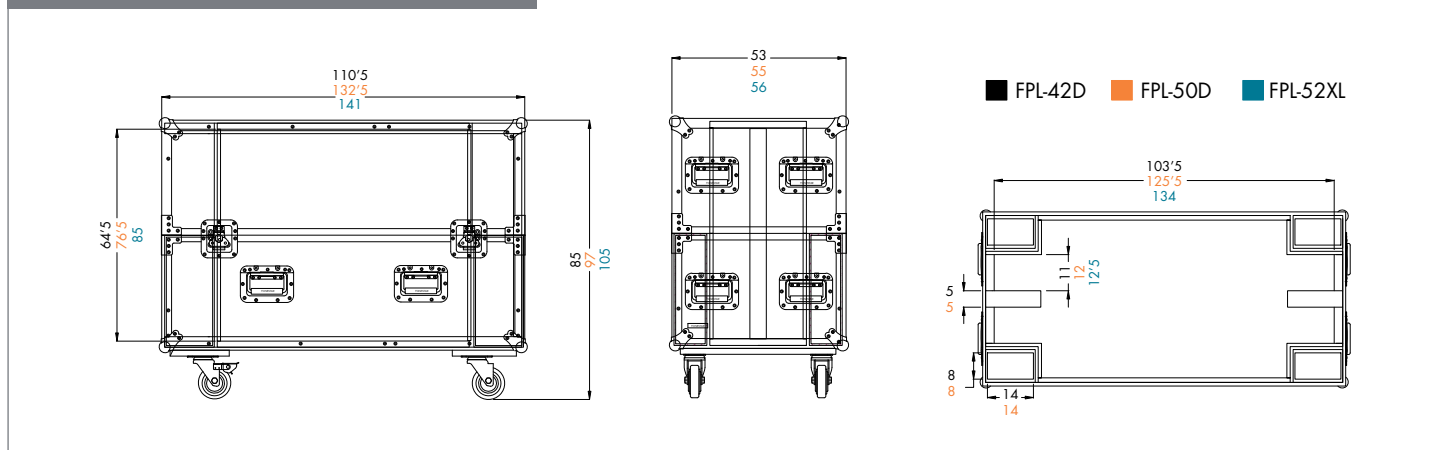

ROAD AND FLIGHT CASES. TROLLEY

Trolley style trunk. Reinforced.



FRT-101

CHARACTERISTICS	Trolley style trunk for transporting and protecting a variety of material. Manufactured in coated plywood and lined with foam. Tough wheels, protective metal corner covers and hermetically closing lid. Robust construction. Black finish
DIMENSIONS	Exterior: 71.5 x 50 x 40 cm depth Interior: 67.5 x 37 x 36 cm depth
WEIGHT	16.5 kg

ROAD AND FLIGHT CASES. BRIEFCASE

FONESTAR

Briefcases for a variety of equipment.



FRT-113

CHARACTERISTICS Transport briefcase with 4 internal divisions. Manufactured in coated plywood. With hermetically closing lid, carrying handle and protective metal corner covers. Robust construction for transporting and protecting varied material. Black finish.

CAPACITY -

DIMENSIONS Exterior: 39.5 x 11.5 x 29.5 cm depth
Interior: 37 x 10 x 28.3 cm depth with four divisions

WEIGHT 2.1 kg



FRT-113M

CHARACTERISTICS Briefcase for transporting wireless FONESTAR microphone systems, mods. MSH-883, MSH-887, MSH-823 and MSH-828 (not included). Manufactured in coated plywood. Hermetically closing lid, carrying handles and protective metal corner covers. Internal foam structure providing maximum support and protection for the professional wireless FONESTAR microphone system. Robust construction. Black enamel finish.

CAPACITY For receiver, hand-held microphone, tie-clip microphone, aeriels, cables, AC/DC adapters, batteries and hand-held microphone covers

DIMENSIONS Exterior: 39.5 x 11.5 x 29.5 cm depth
Interior: 37 x 10 x 28.3 cm depth with foam

WEIGHT 2.1 kg



FRT-115

CHARACTERISTICS Transport case with 3 internal divisions for CDs. Manufactured in coated plywood. With hermetically closing lid, carrying handle and metal protective corner covers. Robust construction for transporting and protecting CDs and varied material. Black finish

CAPACITY -

DIMENSIONS Exterior: 44.5 x 19 x 38 cm depth
Interior: 42.5 x 16.5 x 36 cm depth with 3 divisions of 13.5 x 15 x 36 cm depth for CD, etc.

WEIGHT 3 kg



FRT-116

CHARACTERISTICS Transport case. Manufactured in coated plywood with foam lining. Hermetically closing lid, carrying handle, rubber feet and protective metal corner covers. Robust for transporting and protecting various types of materials. Black finish

DIMENSIONS Exterior: 56.5 x 19.5 x 45 cm depth
Interior: 53 x 16.2 x 41.5 cm depth

WEIGHT 7.4 kg



FRT-117

CHARACTERISTICS Transport case with 16 dismountable spaces for microphones and accessories. Manufactured in coated plywood, with hermetically closing lid, carrying handle and protective metal corner covers. Robust construction for transporting and protecting microphones and varied material. Aluminium finish.

DIMENSIONS Exterior: 47 x 32 x 31 cm depth
Interior: 44.5 x 30 x 28.5 cm depth with dismountable foam divisions for transporting microphones, 28.5 x 28.5 cm.

WEIGHT 5.5 kg



FRT-119

CHARACTERISTICS Transport case. Manufactured in coated plywood. Hermetically closing lid, carrying handle and protective metal corner covers. Robust for transporting and protecting various types of materials. Black finish

DIMENSIONS Exterior: 63 x 30 x 43 cm depth
Interior: 60 x 26 x 41 cm depth

WEIGHT 6 kg

ACCESSORIES. 19" RACK

Front panels for 19" racks and rack cabinets.



FRP-10



FRP-10VEN



FRP-11

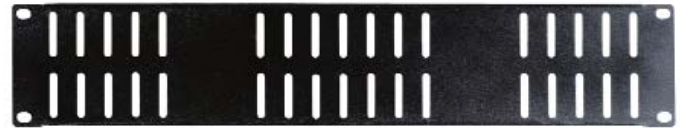

FRP-11VEN



FRP-12

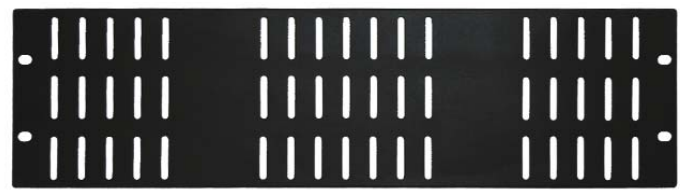

FRP-12VEN

	FRP-10	FRP-10VEN	FRP-11	FRP-11VEN	FRP-12	FRP-12VEN
CHARACTERISTICS	1 U front panel for 19" rack. Black finish	1 U front panel with ventilation slots for 19" rack. Black finish.	2 U front panel for 19" rack. Black finish.	2 U front panel with ventilation slots for 19" rack. Black finish.	3 U front panel for 19" rack. Black finish.	3 U front panel with ventilation slots for 19" rack. Black finish.
DIMENSIONS	483 x 44.5 mm	483 x 44.5 mm	483 x 89 mm	483 x 89 mm	483 x 133.5 mm	483 x 133.5 mm
WEIGHT	0.4 kg	0.3 kg	0.6 kg	0.5 kg	0.8 kg	0.7 kg
ACCESSORIES	Nuts and bolts for assembly	Nuts and bolts for assembly	Nuts and bolts for assembly	Nuts and bolts for assembly	Nuts and bolts for assembly	Nuts and bolts for assembly



FRP-13

CHARACTERISTICS	4 U front panel for 19" rack. Black finish.
DIMENSIONS	483 x 178 mm
WEIGHT	1 kg
ACCESSORIES	Nuts and bolts for assembly

Cable panel for 19" racks and rack cabinets.



FRP-1PC

CHARACTERISTICS	1 U cable panel for 19" rack. Black finish.
DIMENSIONS	483 x 44.5 mm
WEIGHT	0.5 kg
ACCESSORIES	Nuts and bolts for assembly

Front panels, for 19" racks and rack cabinets.



FRP-31XLR



FRP-32SPK



FRP-33M



FRP-34MC



FRP-36M-B



	FRP-31XLR	FRP-32SPK	FRP-33M	FRP-36M-B	FRP-34MC
CHARACTERISTICS	1 U metal mic. hole rack panel for 19" rack, to install 12 XLR sockets. Black finish.	2 U metal mic. hole rack panel for 19" rack, to install 4 speaker connectors. Black finish	2 U metal rack panel for 19" rack, to install 8 Legrand style mosiac series electric devices. Covers for empty spaces included. Black finish	2 U metal rack panel for 19" rack, to install 8 WP series modular connection panels. Protective back with 2 holes for cable output. Covers for empty spaces included. Black finish.	3 U metal rack panel for 19" rack, to install 24 standard uni-polar symmetrical DIN rail electric devices. Covers for empty spaces included. Black finish
DIMENSIONS	483 x 44.5 mm	483 x 89 mm	483 x 89 mm height Window: 360 x 40 mm height	483 x 89 x 60 mm depth Window: 360 x 41 mm height	483 x 133.5 x 60 mm depth Window: 430 x 45 mm height
WEIGHT	0.3 kg	0.6 kg	0.7 kg	1.2 kg	1.6 kg
ACCESSORIES	Nuts and bolts for assembly	Nuts and bolts for assembly	Covers, nuts and bolts for assembly	Lids, nuts and bolts for assembly	Covers, nuts and bolts for assembly

Control cover panels for 19" racks and rack cabinets.



FRP-41G

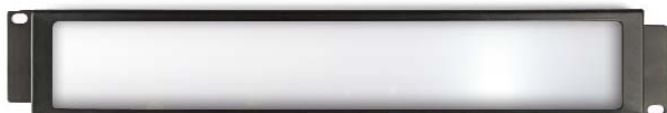

FRP-42G

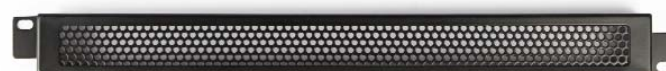

FRP-45M

	FRP-41G	FRP-42G	FRP-45M
CHARACTERISTICS	Control cover panel with 1 U window for 19" rack.	Control cover panel with 2 U window for 19" rack	Control cover panel with 1 U metal grille for 19" rack.
DIMENSIONS	483 x 44.5 x 25 mm depth	483 x 89 x 25 mm depth	483 x 44.5 x 25 mm depth
WEIGHT	0.3 kg	0.6 kg	0.5 kg
ACCESSORIES	Nuts and bolts for assembly	Nuts and bolts for assembly	Nuts and bolts for assembly

ACCESSORIES. 19" RACK

Trays for 19" racks and rack cabinets.

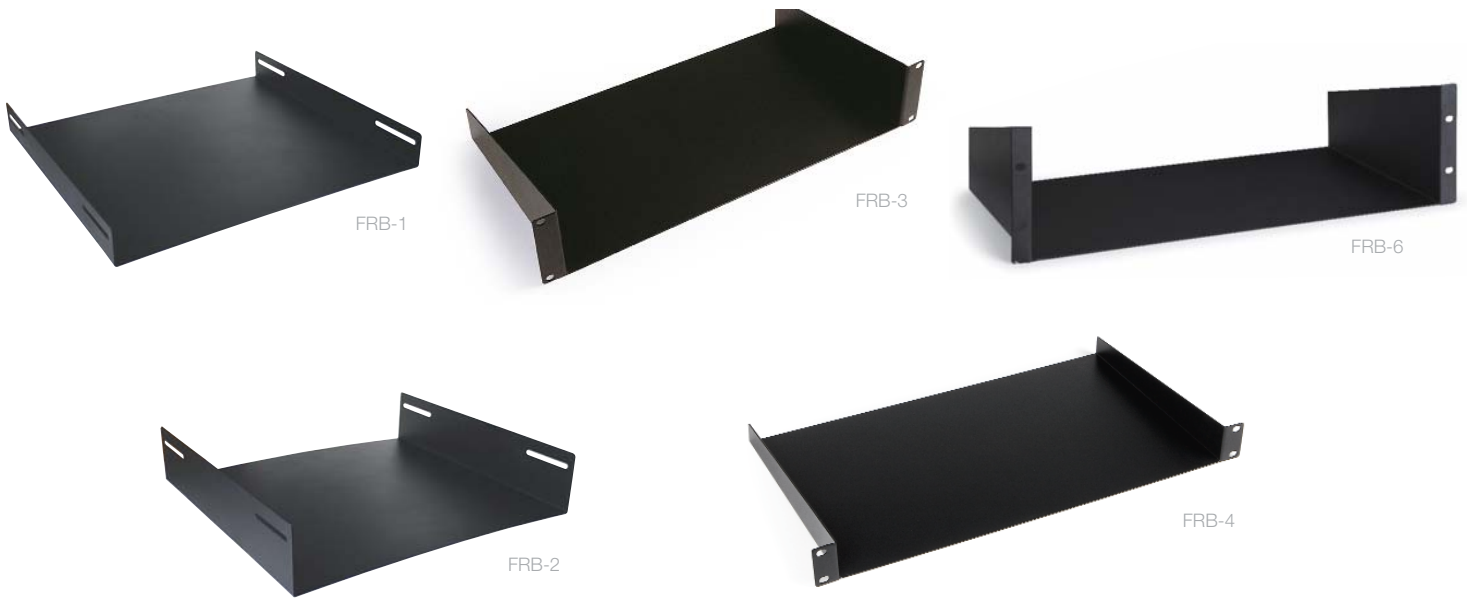

	FRB-1	FRB-2	FRB-3	FRB-4	FRB-6
CHARACTERISTICS	Metal tray with lateral screwing, for 1 U 19" rack. Especially for cabinets in the FONESTAR FRA, FRS, FRM, FRE and FW series. Black finish.	Metal tray with lateral screwing, for 2 U 19" rack. Especially for cabinets in the FONESTAR FRA, FRS, FRM, FRE and FW series. Black finish.	Metal tray with front screwing, for 2 U 19" rack. Black finish.	Metal tray with front screwing, for 1 U 19" rack. Black finish.	Metal tray with front screwing, for 3 U 19" rack. Black finish.
DIMENSIONS	455 x 44.5 x 420 mm depth Internal width: 453 mm	455 x 89 x 420 mm depth Internal width: 453 mm	483 x 89 x 255 mm depth Internal width: 444 mm	483 x 44.5 x 255 mm depth Internal width: 444 mm	483 x 133.5 x 255 mm depth Internal width: 444 mm
WEIGHT	2.7 kg	3.2 kg	1.8 kg	1.6 kg	2 kg
ACCESSORIES	Nuts and bolts for assembly	Nuts and bolts for assembly	Nuts and bolts for assembly	Nuts and bolts for assembly	Nuts and bolts for assembly

Sliding tray and drawers for 19" racks and rack cabinets.



	FRP-14	FRP-15	FRP-16
CHARACTERISTICS	Sliding metal tray with front fastening for 1 U 19" rack. Black finish.	3 U metal drawer for 19" rack, lock with key, front fastening. Suitable for protecting microphones, accessories, etc. Black finish.	6 U metal drawer for 19" rack, lock with key, front fastening. Suitable for protecting microphones, accessories, etc. Black finish.
DIMENSIONS	External: 482 x 44.5 x 346 mm depth Internal: 435 x 27 x 325 mm depth	435 x 133.5 x 350 mm depth	435 x 267 x 350 mm depth
WEIGHT	3 kg	6.2 kg	9 kg
ACCESSORIES	Nuts and bolts for assembly	Nuts and bolts for assembly	Nuts and bolts for assembly

Power distribution unit for 19" racks and rack cabinets.

FRP-8



FRP-8M



FRP-9



FRP-8

FRP-8M

FRP-9

CHARACTERISTICS	1 U power distribution unit for 19" rack. 8 bipolar schuko sockets with earth. Power switch and child control. 1.8 m of 3 x 1.5 mm ² electrical cable with schuko style plug. Manufactured in PVC. Black finish. 230 V, 3500 W maximum, 16 A.	1.5 U metal power distribution unit for 19" rack. 8 bipolar schuko sockets with earth. Power switch and child control. 1.8 m of 3 x 1.5 mm ² electrical cable with schuko style plug. Manufactured in aluminium. Black finish. 230 V, 3500 W maximum, 16 A	1 U power distribution unit for 19" rack. 9 bipolar schuko sockets with earth. Safety shutter 1.8 m of 3 x 1.5 mm ² electrical cable with schuko style plug. Manufactured in PVC. Black finish. 230 V AC, 3500 W maximum, 16 A.
DIMENSIONS	483 x 44.5 x 48 mm depth	483 x 62.5 x 45 mm depth	483 x 44.5 x 48 mm depth
WEIGHT	0.6 kg	1 kg	0.6 kg

Bolt and caged nut for front assembly of equipment in 19" rack

FRP-17

CHARACTERISTICS	Bolt with plastic washer and caged nut for front assembly of equipment in 19" rack. 30 unit blister pack.
-----------------	--



Wheels for 19" rack cabinets and for transport racks.



FRP-21

FRP-22F

FRP-23

FRP-24F

CHARACTERISTICS	3" Ø heavy duty wheel for 19" rack cabinets.	Same as mod. FRP-21, with brake	4" Ø wheel for 19" rack cabinets.	Same as mod. FRP-23, with brake.
WEIGHT	1 kg	1.1 kg	0.7 kg	1 kg